

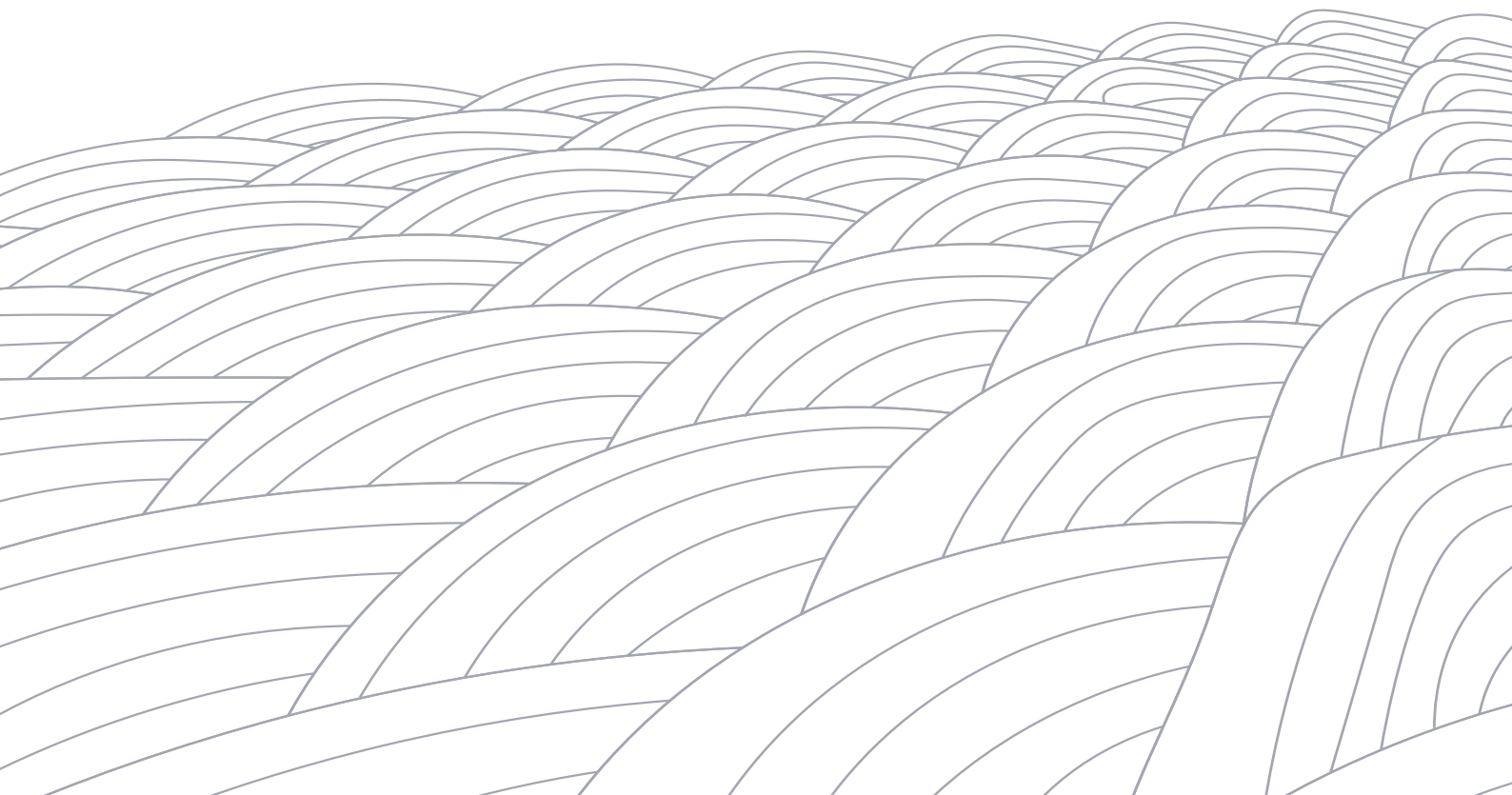

SORST
STRECKMETALL

Lagerkatalog



INHALT

MASCHEGEOMETRIE	4
RAUTENMASCHE	6
EXPERF-MASCHE	16
QUADRATMASCHE	18
LANGSTEG	22
KONTAKT	24

MASCHENGEOMETRIE

Streckgitter sieht nicht immer gleich aus. Im Gegenteil. Aufgrund der großen Vielfalt an Maschengrößen, Materialien oder Weiterverarbeitungsverfahren lassen sich unzählige einzigartige Produkte herstellen. Zur besseren Übersicht wird nicht nur in Maschengröße, sondern auch in Maschenform unterschieden.

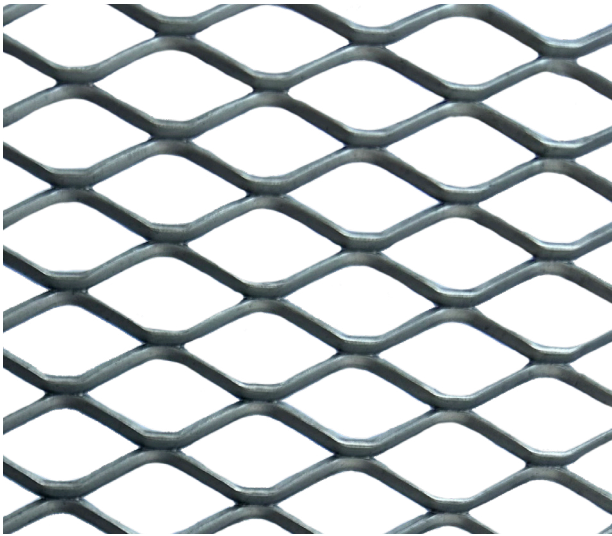

RAUTENMASCHE

In den meisten Fällen haben die Maschen von Streckgitter die Form einer Raute.

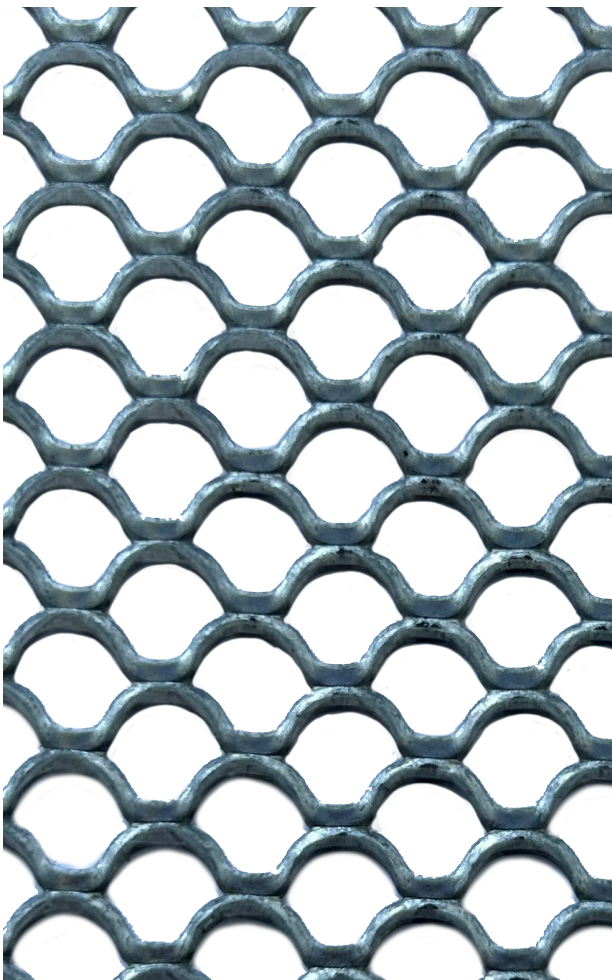

EXPERF-MASCHE

Streckgitter gilt häufig als das günstigere und nachhaltigere Lochblech. Bei einer Experf-Masche ähnelt die Maschenform einem runden Loch.

QUADRATMASSCHE

In der Regel werden Streckgitter in Quadratmasche flachgewalzt, wodurch ein großer freier Querschnitt bei vergleichsweise kleinen Maschenöffnungen entsteht.

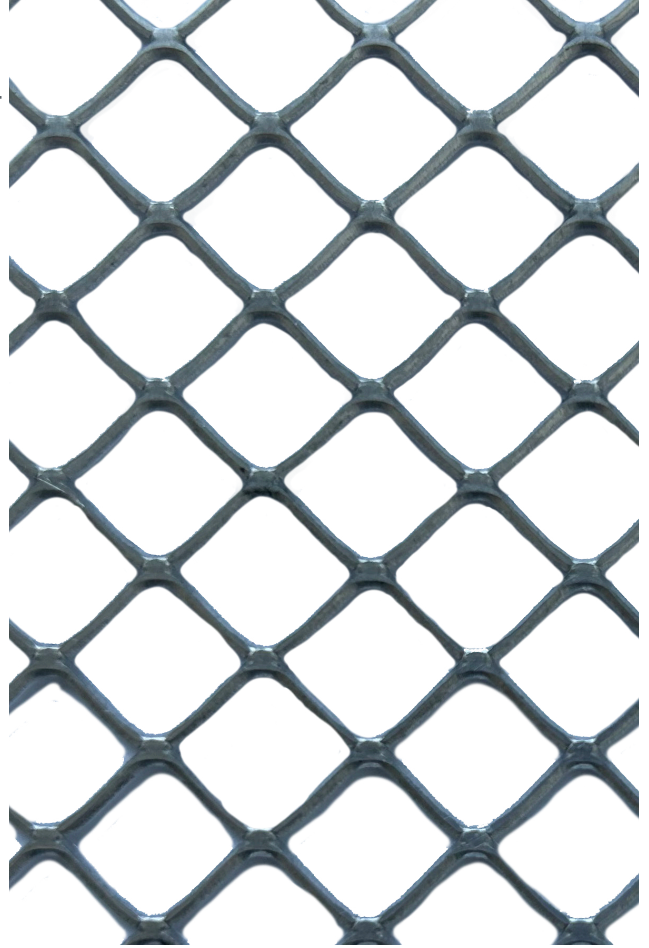

LANGSTEG

Die Langstegmasche fällt deutlich durch ihre besondere Optik auf.

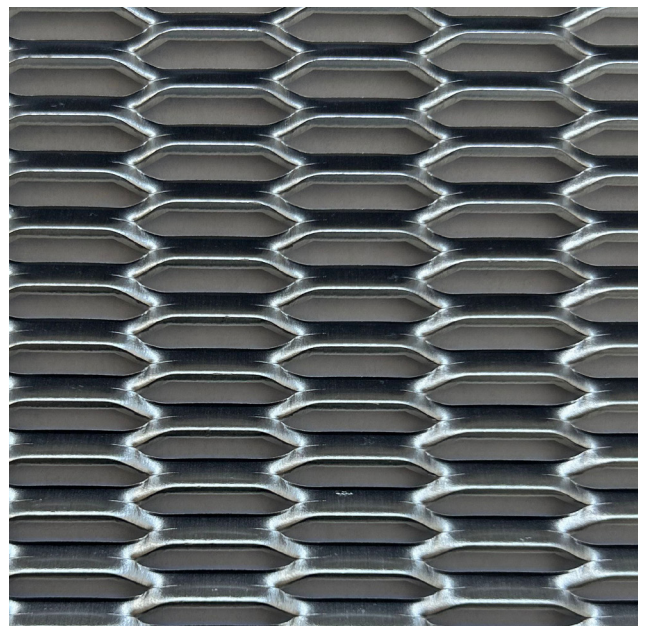

R-6

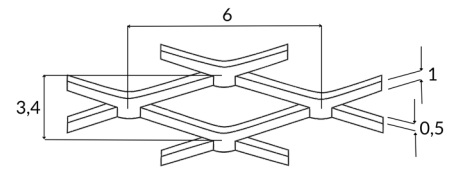
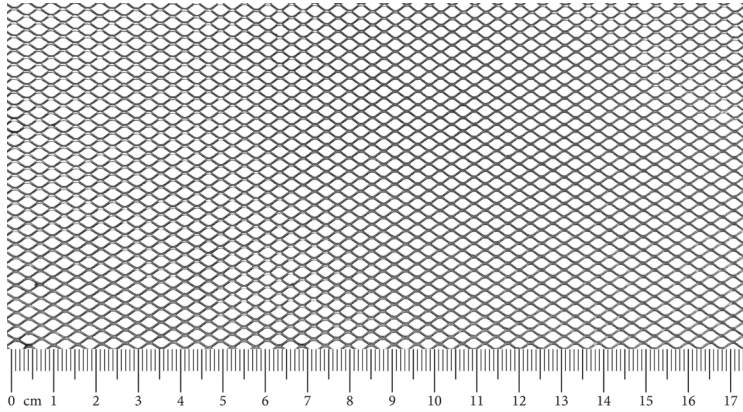

Material	ML in mm	MB in mm	SB in mm	SD in mm	Gitterdicke ca. in mm	Walzart	Freier Querschnitt ca. in %	Gewicht pro Tafel ca. in kg	Format in mm	Artikel- nummer
Stahl	6	3	1	0,5	2,1	roh	33	5,27	1000x2000	1855
Stahl	6	3,7	0,5	0,5	0,7	roh	73	2,17	1000x2000	1856
Stahl sendzimir verzinkt	6	3,4	1	0,5	0,7	roh	41	7,36	1250x2500	4616
Aluminium	6	3,4	0,5	0,5	0,8	roh	71	0,8	1000x2000	4595
Edelstahl	6	3,8	0,8	0,5	0,9	roh	58	3,37	1000x2000	1857

R-8

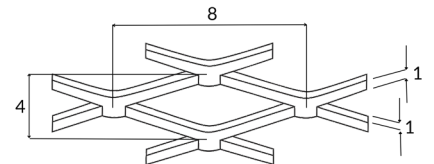
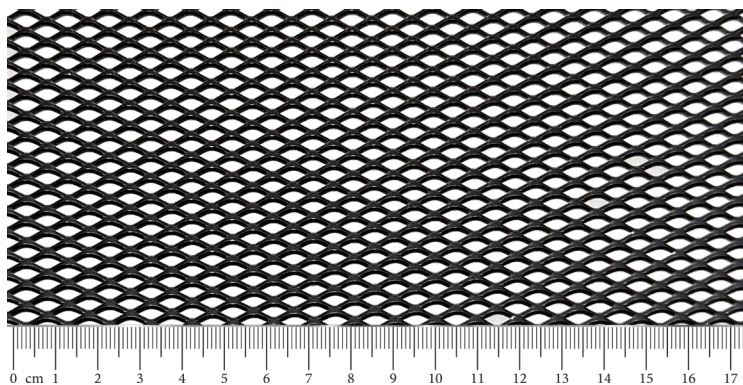

Material	ML in mm	MB in mm	SB in mm	SD in mm	Gitterdicke ca. in mm	Walzart	Freier Querschnitt ca. in %	Gewicht pro Tafel ca. in kg	Format in mm	Artikel- nummer
Stahl	8	4	1	1	2,2	roh	50	8	1000x2000	4618
Aluminium	8	4	1	1	2,2	roh	50	2,7	1000x2000	4617

R-10

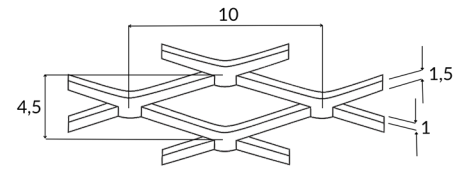
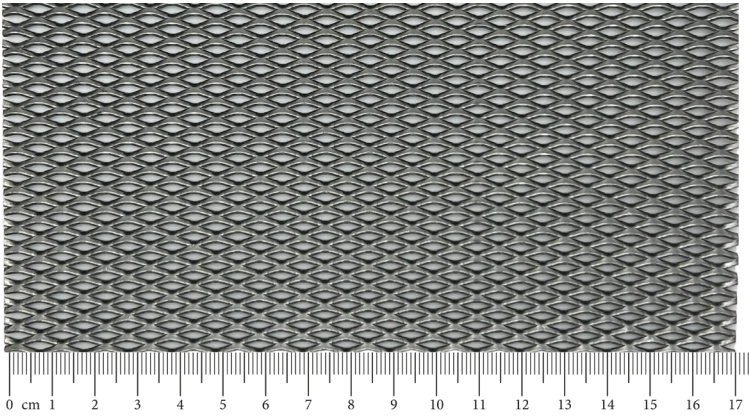

Material	ML in mm	MB in mm	SB in mm	SD in mm	Gitterdicke ca. in mm	Walzart	Freier Querschnitt ca. in %	Gewicht pro Tafel ca. in kg	Format in mm	Artikel- nummer
Stahl	10	4,5	1,5	1	2,1	roh	33	10,67	1000x2000	1824
Aluminium	10	5	1	1	2,2	roh	60	2,16	1000x2000	1823
Edelstahl	10	5	1	0,8	0,8	flach- gewalzt	60	5,12	1000x2000	4629

R-16

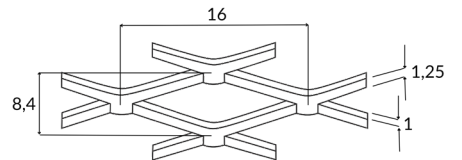
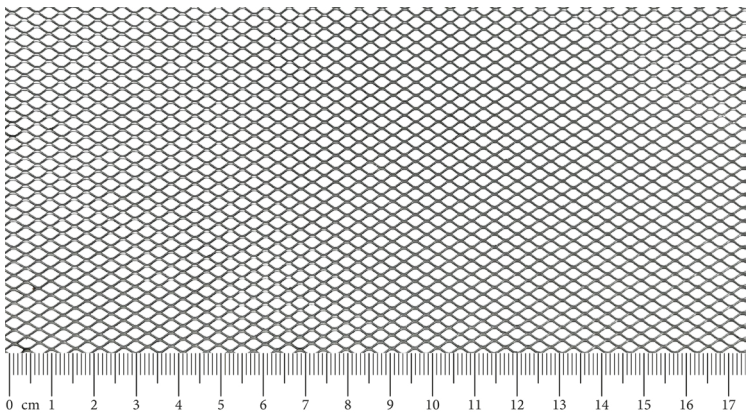

Material	ML in mm	MB in mm	SB in mm	SD in mm	Gitterdicke ca. in mm	Walzart	Freier Querschnitt ca. in %	Gewicht pro Tafel ca. in kg	Format in mm	Artikel- nummer
Stahl	16	8	1,5	1	3	roh	63	9,38	1250x2500	4597
Stahl	16	8	2,5	1,5	3,4	roh	38	23,44	1250x2500	1828
Stahl sendzimir verzinkt	16	8	2	1	2,8	roh	50	12,5	1250x2500	4402
Stahl sendzimir verzinkt	16	8	2,5	1,5	3	roh	38	23,15	1250x2500	1827
Aluminium	16	8	1,5	1	2	roh	63	2,03	1000x2000	4596
Edelstahl	16	8,4	1,25	1	2	roh	70	7,45	1250x2500	1829

R-20

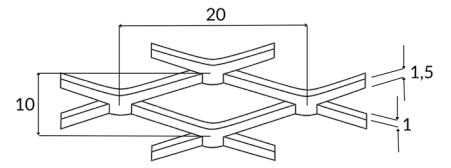
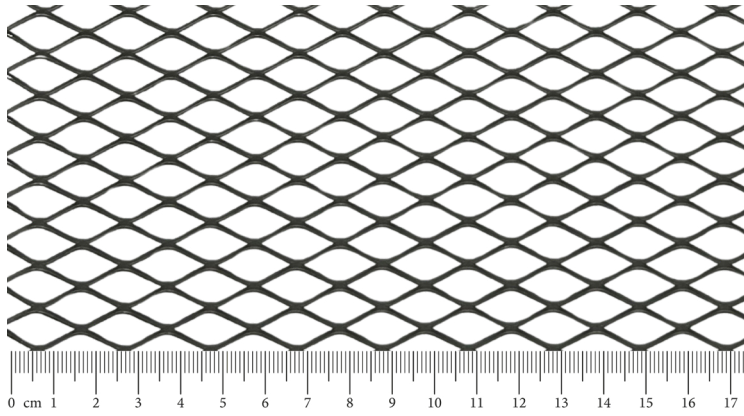

Material	ML in mm	MB in mm	SB in mm	SD in mm	Gitterdicke ca. in mm	Walzart	Freier Querschnitt ca. in %	Gewicht pro Tafel ca. in kg	Format in mm	Artikel- nummer
Stahl	20	10	1,5	1	3,1	roh	70	4,8	1000x2000	1830

R-28-10

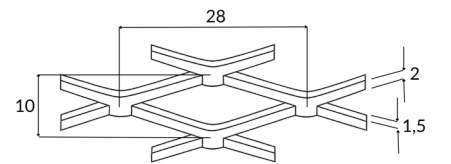
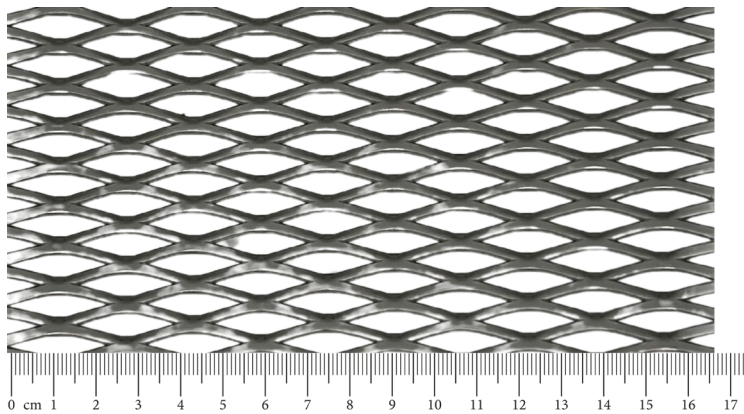

Material	ML in mm	MB in mm	SB in mm	SD in mm	Gitterdicke ca. in mm	Walzart	Freier Querschnitt ca. in %	Gewicht pro Tafel ca. in kg	Format in mm	Artikel- nummer
Stahl	28	10	2	1,5	4,2	roh	60	15	1250x2500	3639

R-28-12

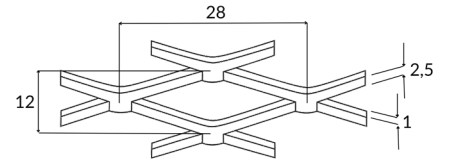
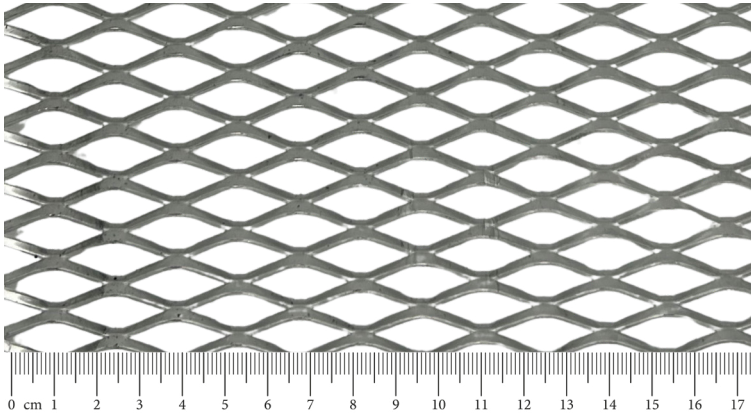

Material	ML in mm	MB in mm	SB in mm	SD in mm	Gitterdicke ca. in mm	Walzart	Freier Querschnitt ca. in %	Gewicht pro Tafel ca. in kg	Format in mm	Artikel- nummer
Stahl	28	12	2,5	1	5,1	roh	58	6,67	1000x2000	1678
Stahl	28	12	2,5	2	5,3	roh	58	13,34	1000x2000	1833
Stahl	28	12	2,5	2	4,8	roh	58	20,84	1250x2500	1835
Stahl	28	12	2,5	2	5,3	roh	58	30	1500x3000	1831
Edelstahl	28	12	2,5	1	3,2	roh	58	6,67	1000x2000	1834

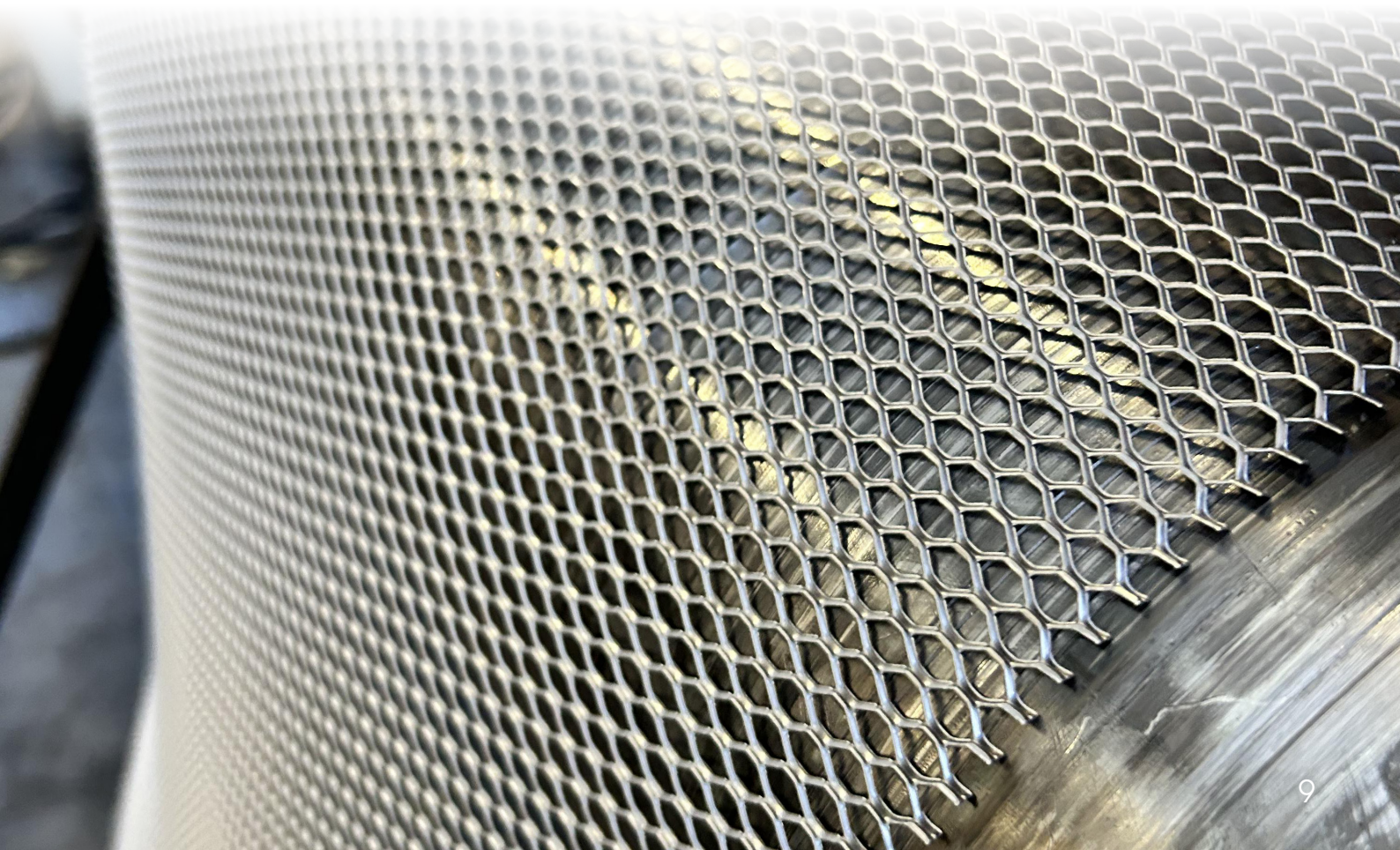

R-42

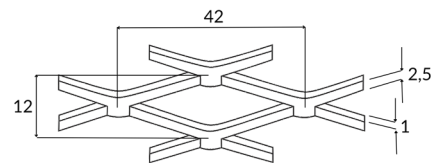
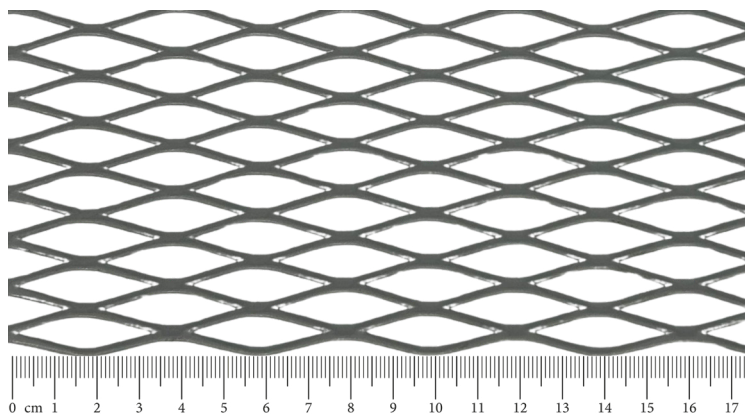

Material	ML in mm	MB in mm	SB in mm	SD in mm	Gitterdicke ca. in mm	Walzart	Freier Querschnitt ca. in %	Gewicht pro Tafel ca. in kg	Format in mm	Artikel- nummer
Stahl	42	12	2,5	1	5,1	roh	58	6,67	1000x2000	1836
Stahl	42	13	3	1,5	6,2	roh	54	10,94	1000x2000	5961
Stahl	42	13	3	2	6	roh	54	14,77	1000x2000	1838
Stahl	42	13	3	2	6	roh	54	23,08	1250x2500	1840
Stahl	43	13	2,5	1,5	5,2	roh	62	14,43	1250x2500	4636
Edelstahl	42	13	3	1,5	6	roh	54	11,08	1000x2000	1839

R-52

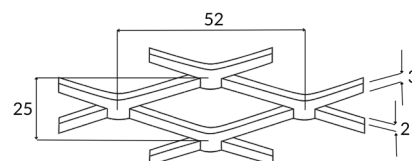
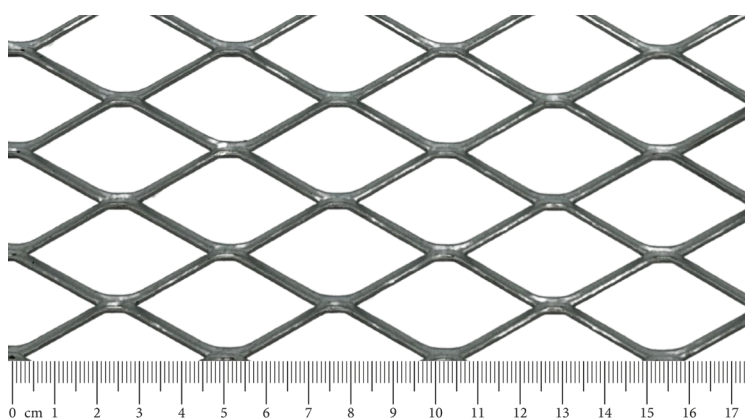

Material	ML in mm	MB in mm	SB in mm	SD in mm	Gitterdicke ca. in mm	Walzart	Freier Querschnitt ca. in %	Gewicht pro Tafel ca. in kg	Format in mm	Artikel- nummer
Stahl	52	25	3	2	6,2	roh	76	12	1250x2500	4611

R-62-21

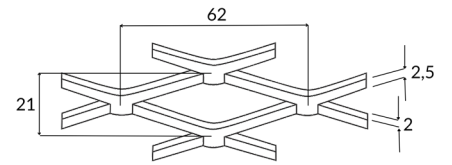
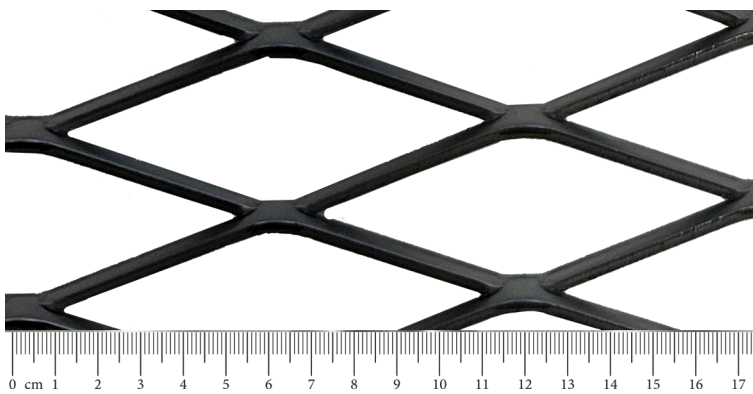

Material	ML in mm	MB in mm	SB in mm	SD in mm	Gitterdicke ca. in mm	Walzart	Freier Querschnitt ca. in %	Gewicht pro Tafel ca. in kg	Format in mm	Artikel- nummer
Stahl	62	21	2,5	2	5,2	roh	76	7,62	1000x2000	1844

R-62-23

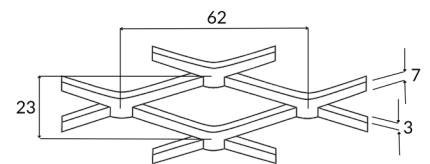
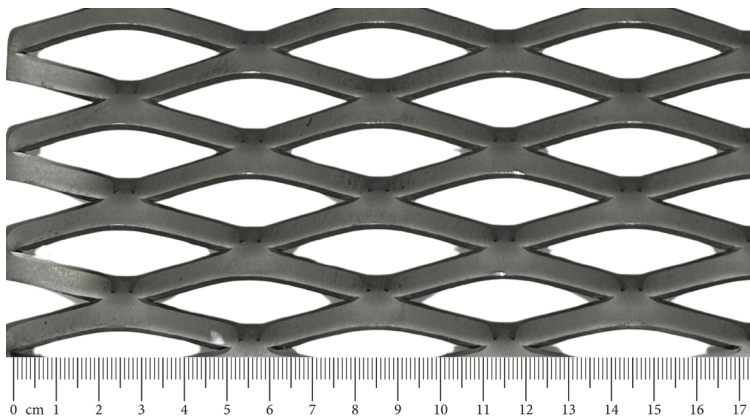

Material	ML in mm	MB in mm	SB in mm	SD in mm	Gitterdicke ca. in mm	Walzart	Freier Querschnitt ca. in %	Gewicht pro Tafel ca. in kg	Format in mm	Artikel- nummer
Stahl	62	23	7	3	12	roh	39	29,22	1000x2000	1846
Stahl	62	23	7	3	12	roh	39	45,66	1250x2500	1847
Aluminium	62	23	7	3	11,5	roh	39	9,87	1000x2000	1845

R-62-25

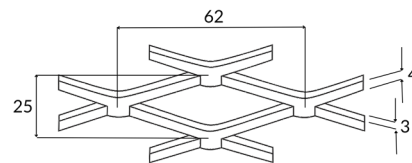
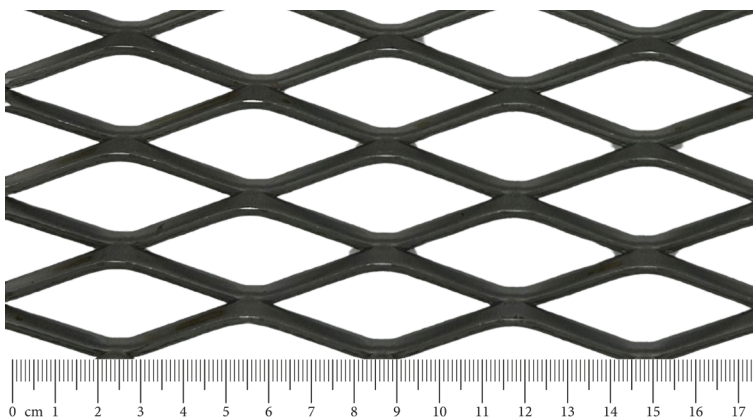

Material	ML in mm	MB in mm	SB in mm	SD in mm	Gitterdicke ca. in mm	Walzart	Freier Querschnitt ca. in %	Gewicht pro Tafel ca. in kg	Format in mm	Artikel- nummer
Stahl	62	25	3	3	6,3	roh	76	11,52	1000x2000	1848
Stahl	62	25	4	3	8,4	roh	68	15,36	1000x2000	1851
Stahl	62	25	4	3	8,4	roh	68	24	1250x2500	1853
Stahl	62	25	4	3	8,4	roh	68	34,56	1500x3000	4614

R-76-3

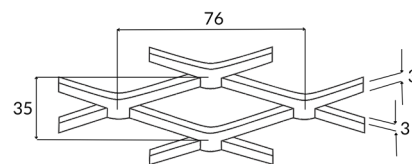
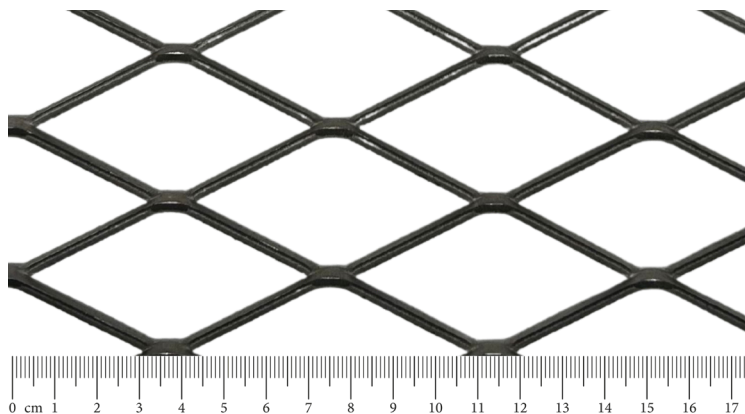

Material	ML in mm	MB in mm	SB in mm	SD in mm	Gitterdicke ca. in mm	Walzart	Freier Querschnitt ca. in %	Gewicht pro Tafel ca. in kg	Format in mm	Artikel- nummer
Stahl	76	35	3	3	6,2	roh	83	12,86	1250x2500	1858

R-76-11

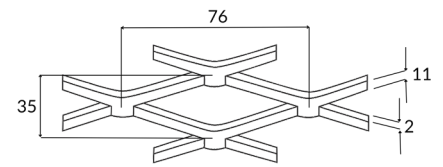
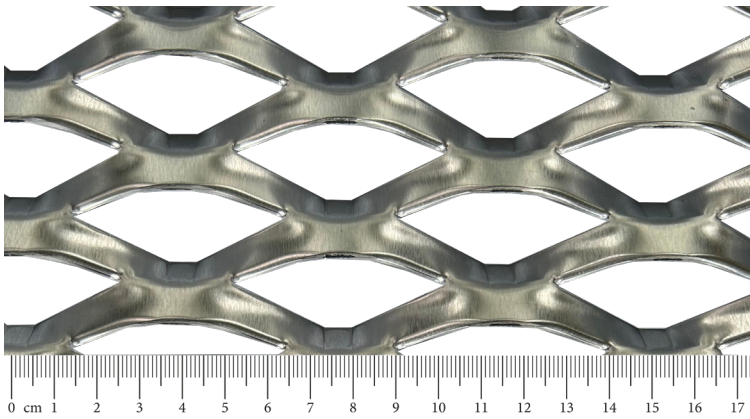

Material	ML in mm	MB in mm	SB in mm	SD in mm	Gitterdicke ca. in mm	Walzart	Freier Querschnitt ca. in %	Gewicht pro Tafel ca. in kg	Format in mm	Artikel- nummer
Aluminium	76	35	11	2	14,9	roh	37	15,28	1500x3000	3396

R-90

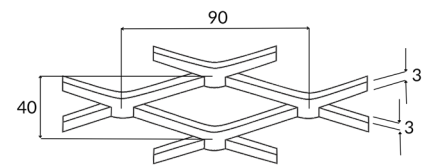
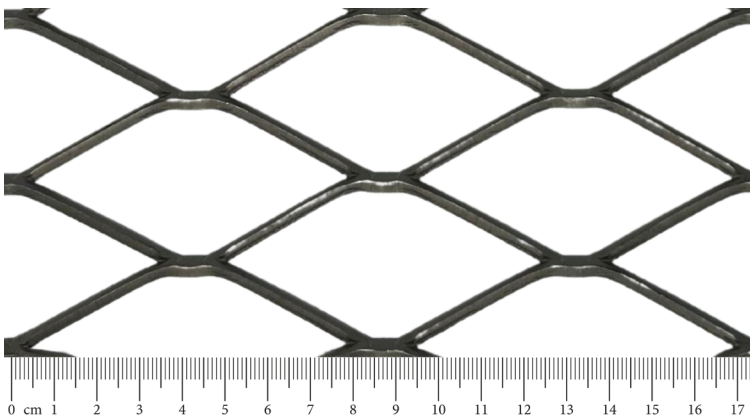

Material	ML in mm	MB in mm	SB in mm	SD in mm	Gitterdicke ca. in mm	Walzart	Freier Querschnitt ca. in %	Gewicht pro Tafel ca. in kg	Format in mm	Artikel- nummer
Stahl	90	40	3	3	6,2	roh	85	11,25	1250x2500	1859

R-110

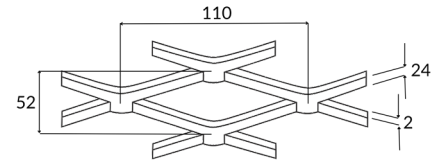
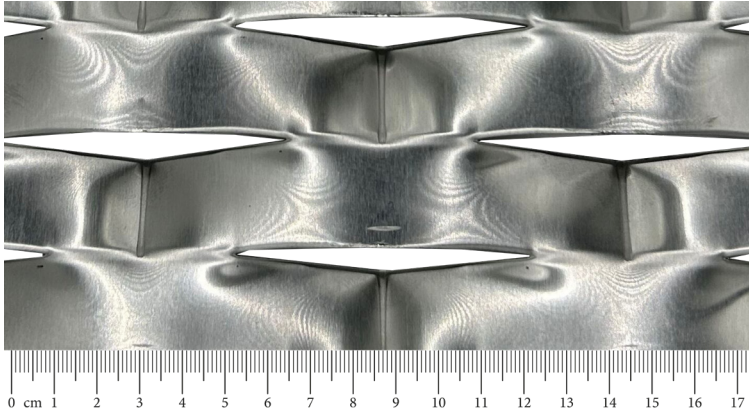

Material	ML in mm	MB in mm	SB in mm	SD in mm	Gitterdicke ca. in mm	Walzart	Freier Querschnitt ca. in %	Gewicht pro Tafel ca. in kg	Format in mm	Artikel- nummer
Aluminium	110	52	24	2	20	roh	8	9,97	1000x2000	1866

R-115-40

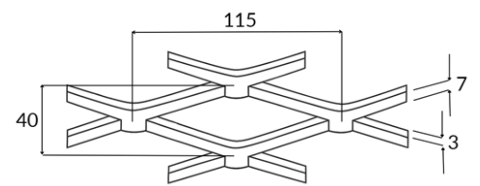
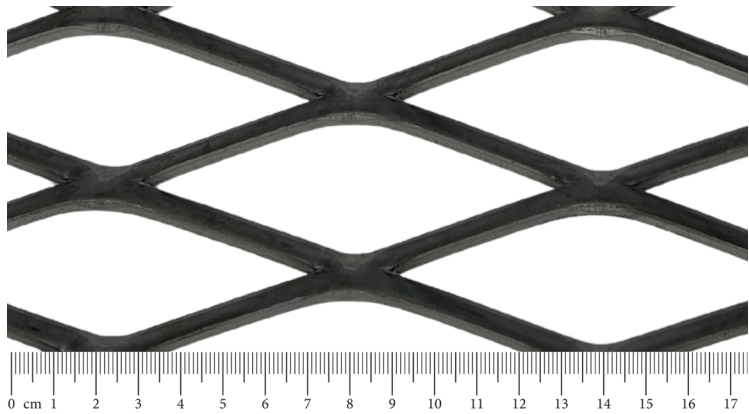

Material	ML in mm	MB in mm	SB in mm	SD in mm	Gitterdicke ca. in mm	Walzart	Freier Querschnitt ca. in %	Gewicht pro Tafel ca. in kg	Format in mm	Artikel- nummer
Stahl	115	40	7	3	14,3	roh	65	16,8	1000x2000	4204

R-115-48

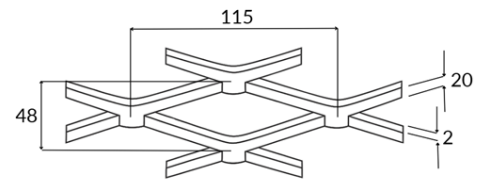
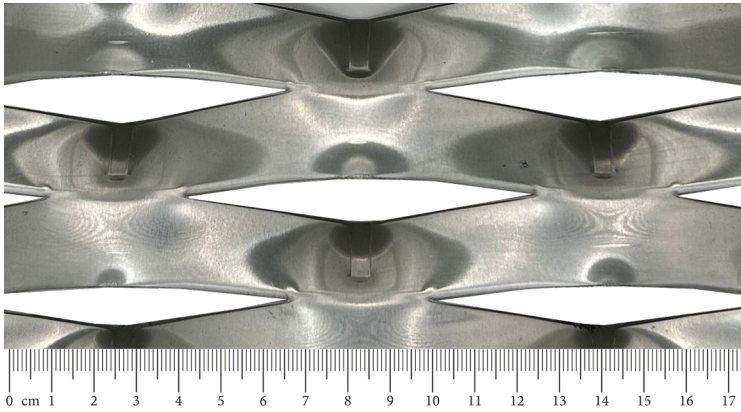

Material	ML in mm	MB in mm	SB in mm	SD in mm	Gitterdicke ca. in mm	Walzart	Freier Querschnitt ca. in %	Gewicht pro Tafel ca. in kg	Format in mm	Artikel- nummer
Aluminium	115	48	20	2	19,6	roh	17	20,25	1500x3000	4615



E-5

Lochdurchmesser entspricht ca. 2,5 mm

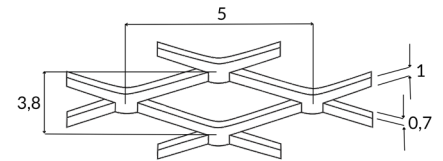
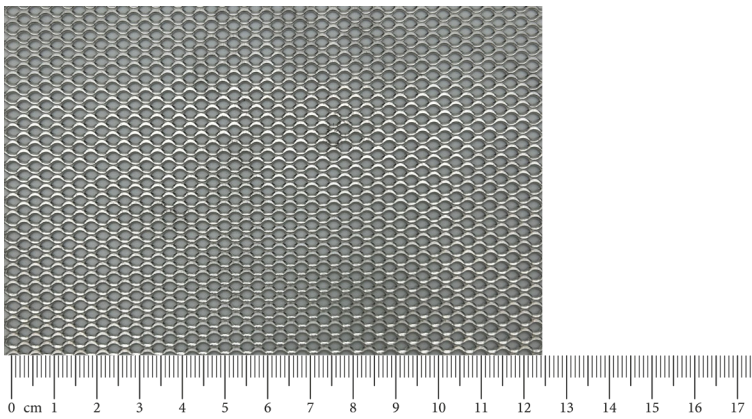

Material	ML in mm	MB in mm	SB in mm	SD in mm	Gitterdicke ca. in mm	Walzart	Freier Querschnitt ca. in %	Gewicht pro Tafel ca. in kg	Format in mm	Artikel- nummer
Stahl sendzimir verzinkt	5	3,8	1	0,7	0,7	flach- gewalzt	47	5,9	1000x2000	1308
Stahl sendzimir verzinkt	5	3,8	1,1	1	1	flach- gewalzt	42	9,27	1000x2000	1309

E-10

Lochdurchmesser entspricht ca. 5 mm

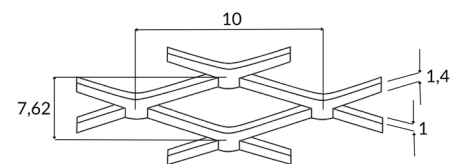
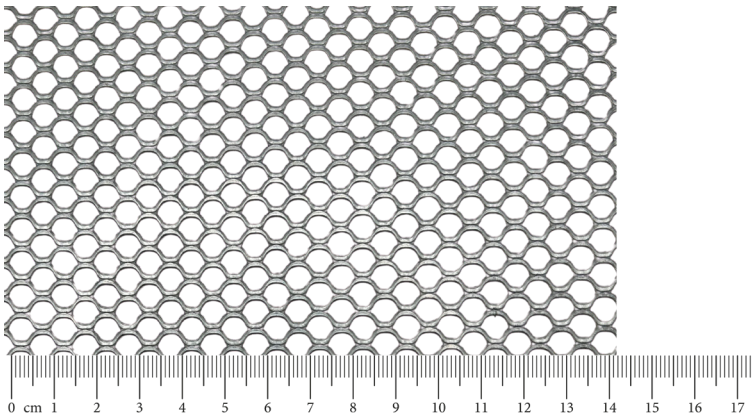

Material	ML in mm	MB in mm	SB in mm	SD in mm	Gitterdicke ca. in mm	Walzart	Freier Querschnitt ca. in %	Gewicht pro Tafel ca. in kg	Format in mm	Artikel- nummer
Stahl sendzimir verzinkt	10	7,62	14	0,7	0,7	flachge- walzt	63	4,12	1000x2000	1306
Stahl sendzimir verzinkt	10	7,62	1,4	1	1	flachge- walzt	63	5,88	1000x2000	1761
Stahl sendzimir verzinkt	10	7,62	1,4	1	1	flachge- walzt	63	9,19	1250x2500	1303
Stahl sendzimir verzinkt	10	7,62	1,4	1	1	flachge- walzt	63	13,23	1500x3000	1316
Aluminium	10	7,62	1,4	1	1	flachge- walzt	63	1,99	1000x2000	1317

E-20

Lochdurchmesser entspricht ca. 10 mm

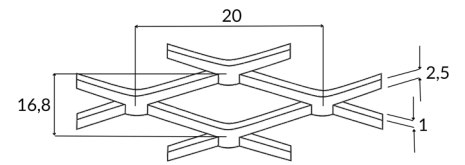
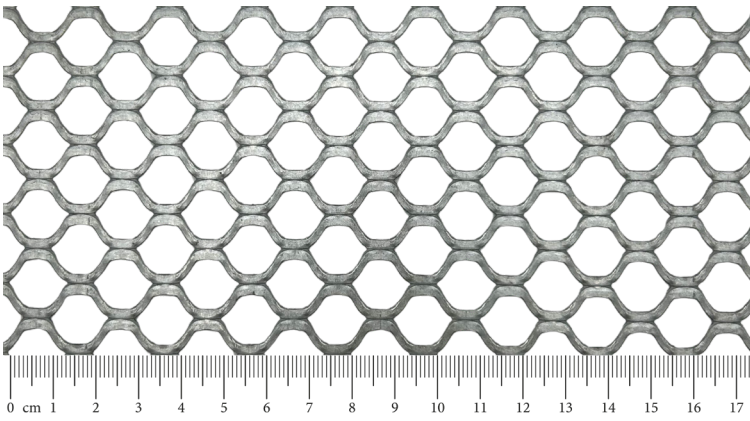

Material	ML in mm	MB in mm	SB in mm	SD in mm	Gitterdicke ca. in mm	Walzart	Freier Querschnitt ca. in %	Gewicht pro Tafel ca. in kg	Format in mm	Artikel- nummer
Stahl sendzimir verzinkt	20	16,8	2,5	1	1	flach- gewalzt	70	4,77	1000x2000	1307

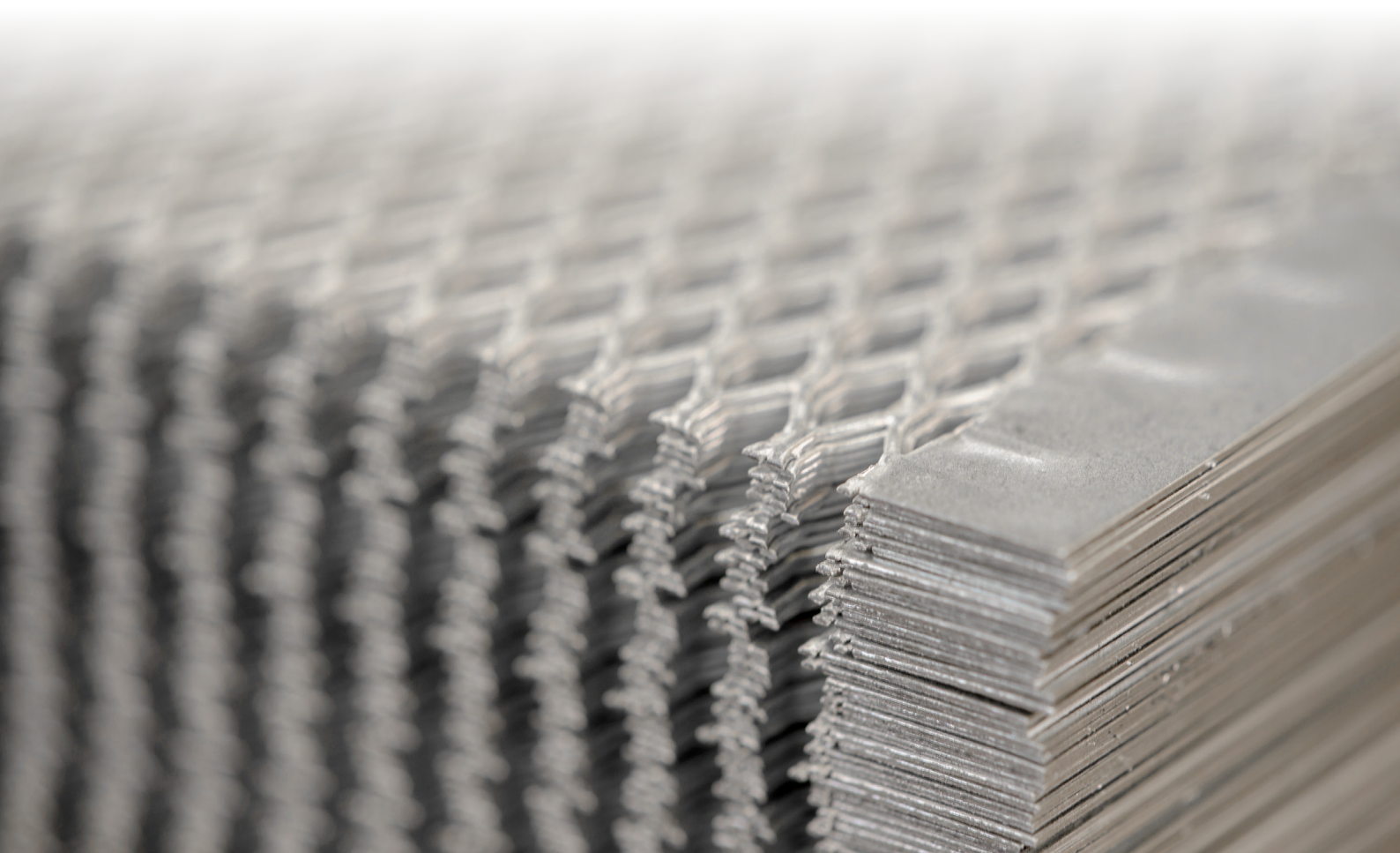

QUADRATMASCHE

Q-8

Lochdurchmesser entspricht ca. 5 mm

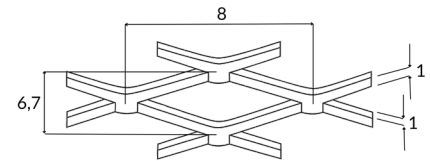
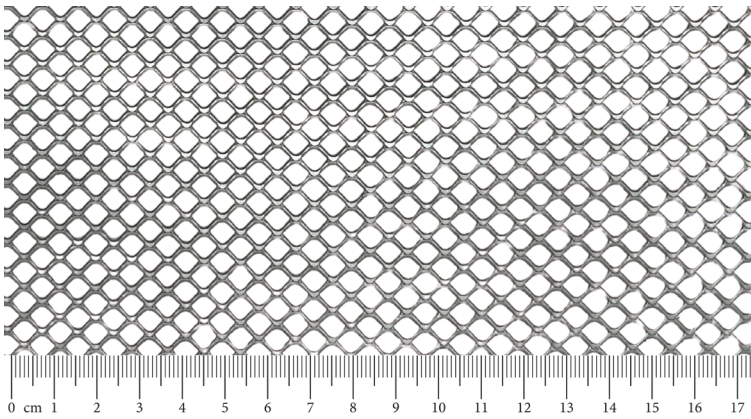

Material	ML in mm	MB in mm	SB in mm	SD in mm	Gitterdicke ca. in mm	Walzart	Freier Querschnitt ca. in %	Gewicht pro Tafel ca. in kg	Format in mm	Artikel- nummer
Stahl sendzimir verzinkt	8	6,7	1	1	1	flach- gewalzt	70	4,78	1000x2000	1821

Q-10

Lochdurchmesser entspricht ca. 6 mm

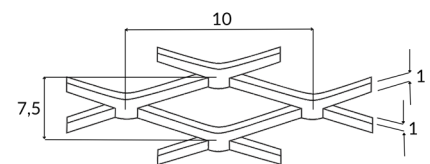
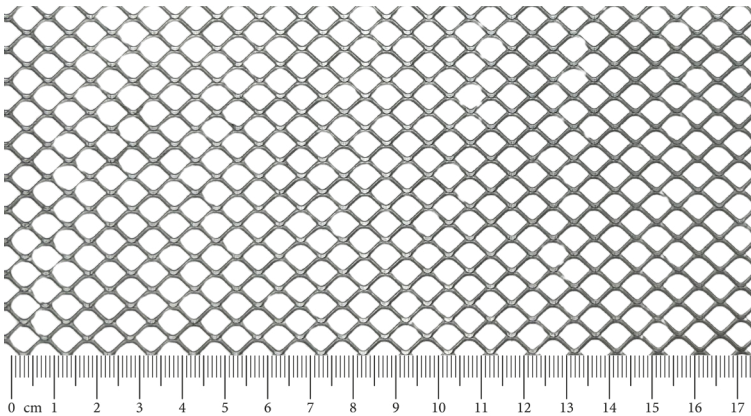

Material	ML in mm	MB in mm	SB in mm	SD in mm	Gitterdicke ca. in mm	Walzart	Freier Querschnitt ca. in %	Gewicht pro Tafel ca. in kg	Format in mm	Artikel- nummer
Stahl sendzimir verzinkt	10	7,5	1	1	1	flach- gewalzt	73	4,27	1000x2000	1313

Q-14

Lochdurchmesser entspricht ca. 8 mm

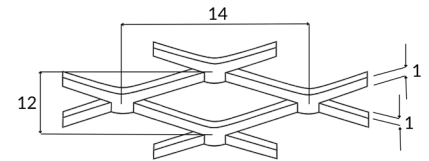
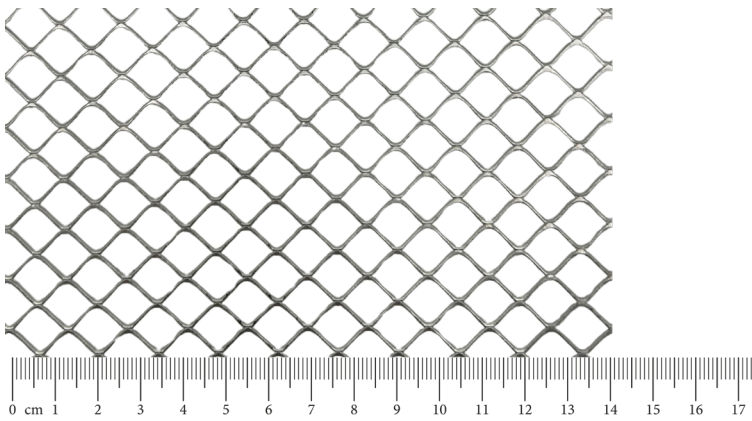

Material	ML in mm	MB in mm	SB in mm	SD in mm	Gitterdicke ca. in mm	Walzart	Freier Querschnitt ca. in %	Gewicht pro Tafel ca. in kg	Format in mm	Artikel- nummer
Aluminium	14	12	1	1	1	flach- gewalzt	83	0,9	1000x2000	1314

Q-16

Lochdurchmesser entspricht ca. 10 mm

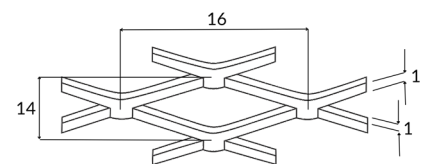
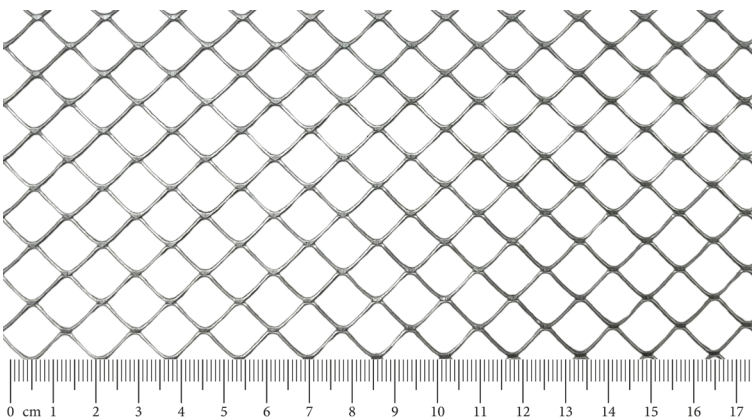

Material	ML in mm	MB in mm	SB in mm	SD in mm	Gitterdicke ca. in mm	Walzart	Freier Querschnitt ca. in %	Gewicht pro Tafel ca. in kg	Format in mm	Artikel- nummer
Stahl sendzimir verzinkt	16	14	1	1	1	flach- gewalzt	86	2,29	1000x2000	1320

Q-20

Lochdurchmesser entspricht ca. 12 mm

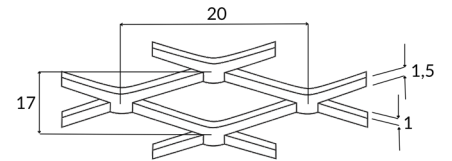
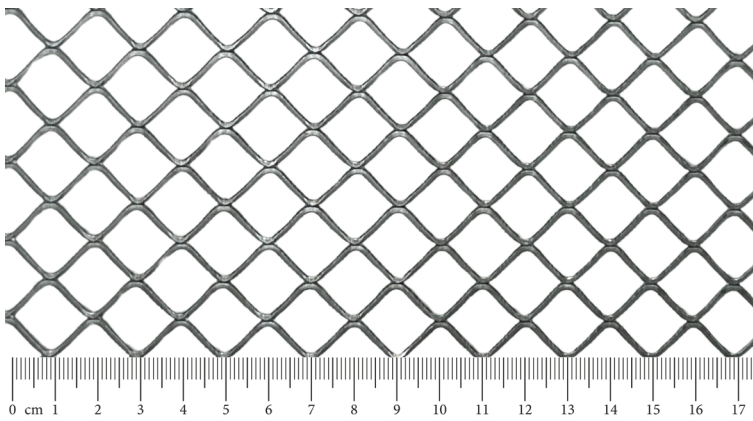

Material	ML in mm	MB in mm	SB in mm	SD in mm	Gitterdicke ca. in mm	Walzart	Freier Querschnitt ca. in %	Gewicht pro Tafel ca. in kg	Format in mm	Artikel- nummer
Stahl sendzimir verzinkt	20	17	1,5	1	1	flach- gewalzt	82	2,83	1000x2000	1820

Q-30

Lochdurchmesser entspricht ca. 17 mm

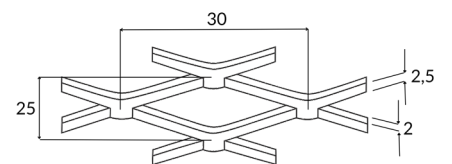
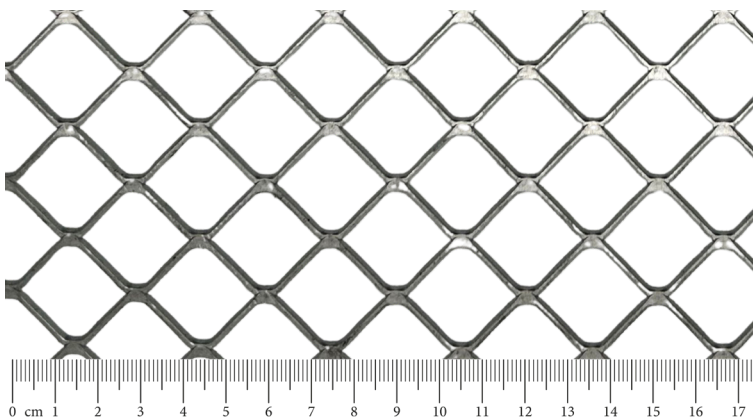

Material	ML in mm	MB in mm	SB in mm	SD in mm	Gitterdicke ca. in mm	Walzart	Freier Querschnitt ca. in %	Gewicht pro Tafel ca. in kg	Format in mm	Artikel- nummer
Stahl	30	25	2,5	2	2	flach- gewalzt	80	10	1250x2500	4600

Q-40

Lochdurchmesser entspricht ca. 23 mm

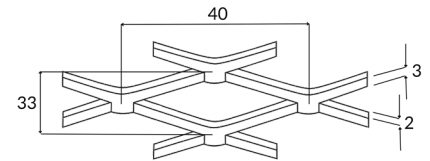
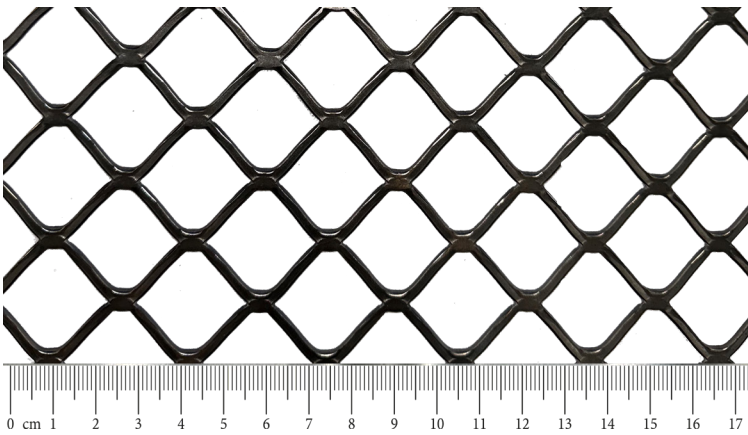

Material	ML in mm	MB in mm	SB in mm	SD in mm	Gitterdicke ca. in mm	Walzart	Freier Querschnitt ca. in %	Gewicht pro Tafel ca. in kg	Format in mm	Artikel- nummer
Stahl	40	33	3	2	2	flach- gewalzt	82	5,82	1000x2000	4607

Q-50

Lochdurchmesser entspricht ca. 30 mm

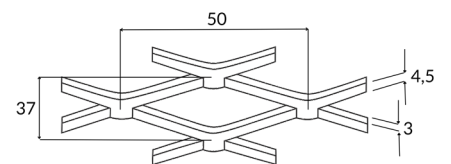
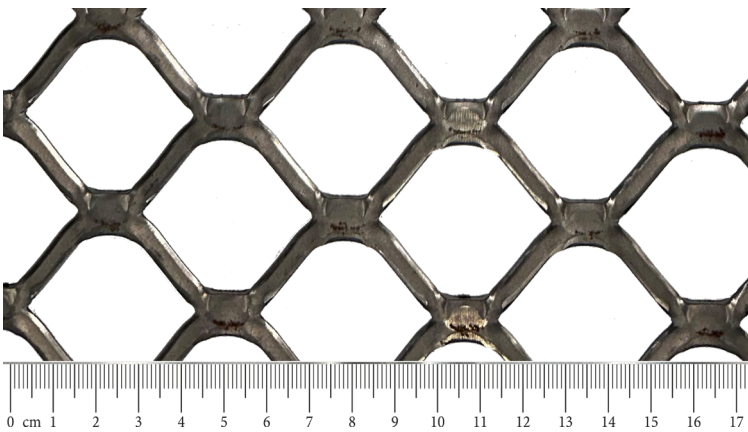

Material	ML in mm	MB in mm	SB in mm	SD in mm	Gitterdicke ca. in mm	Walzart	Freier Querschnitt ca. in %	Gewicht pro Tafel ca. in kg	Format in mm	Artikel- nummer
Stahl	50	37	4,5	3	3	flach- gewalzt	76	11,68	1000x2000	4621

L-45

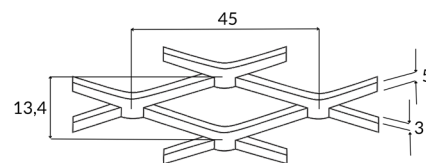
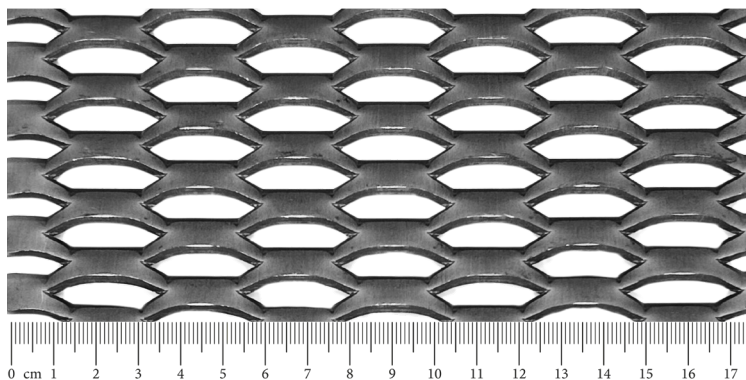

Material	ML in mm	MB in mm	SB in mm	SD in mm	Gitterdicke ca. in mm	Walzart	Freier Querschnitt ca. in %	Gewicht pro Tafel ca. in kg	Format in mm	Artikel- nummer
Stahl	45	13,4	5	3	8	roh	25	55,98	1250x2500	1841

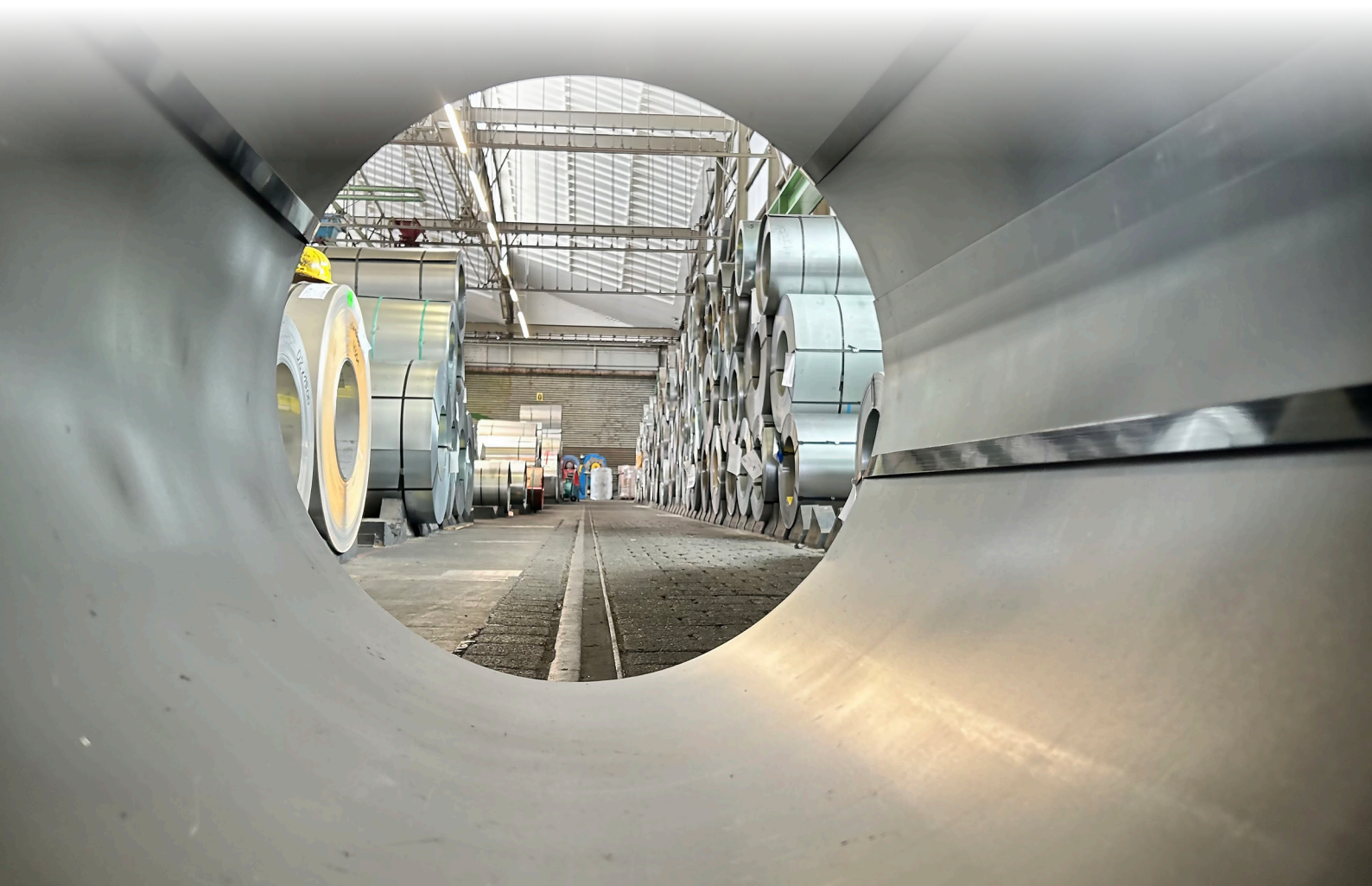



KONTAKT

Sorst Streckmetall GmbH
Wohlenbergstr. 11
D - 30179 Hannover

Tel: +49 (0) 511 67 67 56 50
Fax: +49 (0) 511 67 67 56 56

E-mail: info@sorst.de
www.sorst.de

